



WATER PUMPS
MADE IN ITALY

2020

GENERAL CATALOGUE
CATALOGO GENERALE

ELETTROPOMPE SOMMERSE INOX
PER ACQUE CARICHE

STAINLESS STEEL SUBMERSIBLE PUMPS
FOR DIRTY WATER

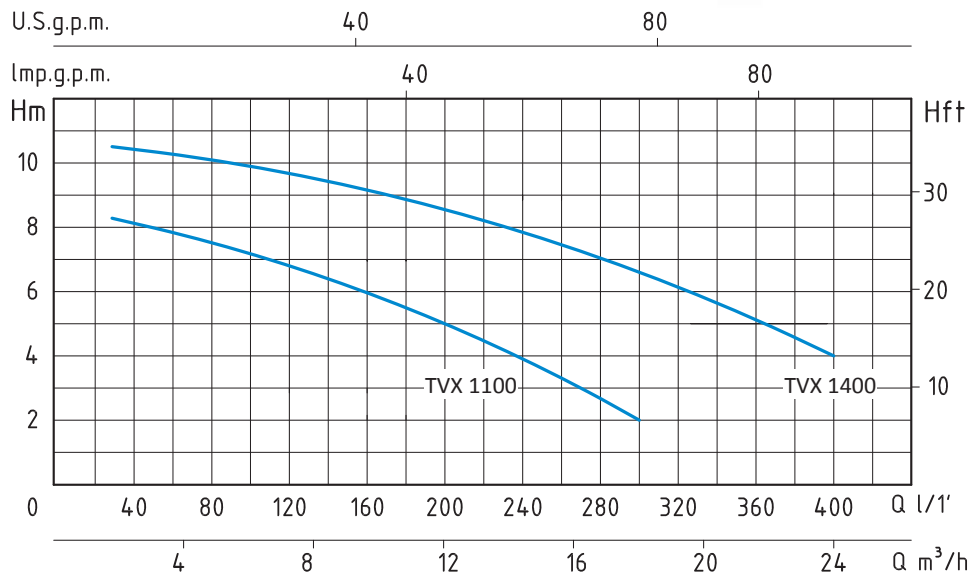

TVX - 50 HZ - 1 PHASE

TIPO TYPE	POTENZA ASSORBITA INPUT POWER	AMPERE	Condensatore Capacitor	Q = PORTATA - CAPACITY											
				m³/h	1,8	3,6	5,4	7,2	9	12	15	18	21	24	
Monofase Single-phase	P1	Monofase Single-phase	µf	lt/1'	30	60	90	120	150	200	250	300	350	400	
	Watt			Prevalenza manometrica totale in m.C.A. - Total head in meters w.c.											
TVX 1100	1100 W	5	16	H (m)	8,2	8	7,5	7	6,5	5	3,9	2			
TVX 1400	1400 W	6,5	20	H (m)	10,5	10,2	10	9,2	8,8	8,5	7,8	6,2	5	4	

APPLICAZIONI

Elettropompe sommersa inox per drenaggio con girante in acciaio inox adatte per svuotamento di fosse di decantazione e per pompaggio di acque luride ad uso domestico e civile.

LIMITI D'IMPIEGO

- Temperatura liquido fino a 35°C (per un uso domestico secondo EN 60335-2-41)
- Temperatura max. liquido: 35°C (per altri impieghi)
- Massima profondità d'immersione 5 mt.
- Passaggio solidi Ø 35 mm
- Livello min. d'aspirazione 65 mm
- Servizio continuo

MOTORE

- Monofase 230V-50Hz
- Doppia camera con motore in bagno d'olio per raffreddamento e lubrificazione cuscinetti
- Tenuta meccanica in bagno d'olio
- Condensatore permanente inserito
- Isolamento Classe F
- Protezione IP 68

MATERIALI

- Maniglia Acciaio Inox AISI 304
- Cassa motore Acciaio Inox AISI 304
- Corpo pompa Acciaio Inox AISI 304
- Girante Acciaio Inox AISI 304
- Griglia aspirazione Acciaio Inox AISI 304
- Albero motore Acciaio Inox AISI 304
- Tenuta meccanica Ceramica/Grafite/NBR



APPLICATION

Drainage submersible stainless steel water pumps with stainless steel impeller.

Able to drain decanting cesspools and to pump waste water for domestic and civil purposes.

OPERATING CONDITIONS

- Liquid temperature up to 35°C (for home use according to EN 60335-2-41)
- Temperature max. liquid: 35°C (for other uses)
- Maximum immersion depth 5 mt.
- Grain size inlet Ø 35 mm
- Min. suction level 65 mm
- Continuous duty

MOTOR

- Single-phase 230V-50Hz
- Dual chamber with oil bath motor for cooling and bearing lubrication
- Mechanical seal in oil bath
- Permanent split capacitor
- Insulation Class F
- Protection IP 68

MATERIALS

- Handle Stainless Steel AISI 304
- Motor casing Stainless Steel AISI 304
- Pump body Stainless Steel AISI 304
- Impeller Stainless Steel AISI 304
- Suction grid Stainless Steel AISI 304
- Shaft with rotor Stainless Steel AISI 304
- Mechanical seal Ceramic/Graphite/NBR

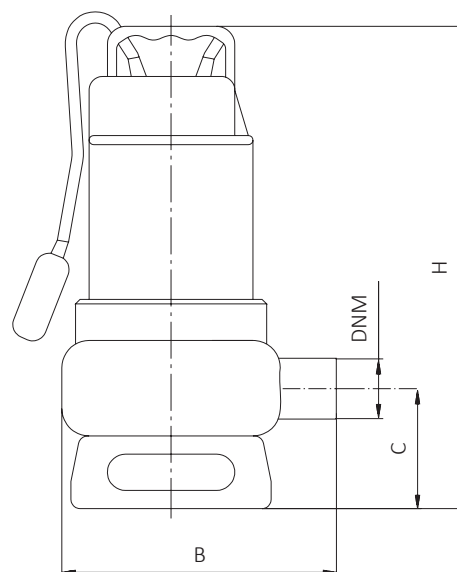

TIPO TYPE	DIMENSIONI mm- DIMENSIONS mm					DIMENSIONI DIMENSIONS mm			PESO WEIGHT Kg
	B	C	H	DNM	CAVO CABLE	P	L	H	
Monofase Single-phase	B	C	H	DNM	CAVO CABLE	P	L	H	Kg
TVX 1100	213	92	366	1" ½	10 mt H07RNF	195	232	415	10,2
TVX 1400	213	92	366	2"	10 mt H07RNF	195	232	415	11,5